



# Circuit/Packet eXchange (CPX) Module Set

## Integrated IP Technology for DNX-11/88 Platforms

### Simplifying the Work of Network Migration

Migrating from TDM to IP technology is easy to talk about, hard to do. Network operators need practical, cost-efficient ways to accommodate traffic growth, streamline provisioning of voice and data services, and move non-disruptively toward next-generation network architectures.

The Circuit/Packet eXchange (CPX) module set adds a unique IP forwarding engine to DNX-11/88 Multiservice Cross-Connect platforms, simplifying the work of network migration with Sycamore's trademark combination of innovation and reliability. This industry-first integration of circuit/packet functionality on a carrier-class cross-connect supports a seamless transition from TDM to IP technology in both fixed line and mobile networks. CPX also solves many operational challenges of signaling network migration, enabling circuit-expert SS7 engineers to maintain control of packet-based Sigtran diagnostics and troubleshooting.

### Cost-Efficient IP Technology Integration

The DNX-11/88 with a CPX IP interface provides single chassis support for circuit or packet traffic, up to 1024 DS0 or 32 T1/E1 virtual WAN connections, and is fully interoperable with Ethernet/PPP-compliant routers and signaling elements (STP and SCP). Network operators can consolidate network management traffic, user data traffic, and TDM circuit data onto a single transport medium, leveraging the DNX cross-connect fabric to segregate or integrate circuit and packet streams on a per-DS0 basis. This level of performance and scalability reduces CapEx and OpEx, simplifies network management, and increases configuration flexibility.

CPX aggregates circuit traffic onto higher-speed uplinks in traditional DCS grooming fashion; it also routes downstream traffic from multiple networks into a statistically multiplexed packet-switched uplink to optimize bandwidth in the packet network. Since both circuit and packet functions are located in the same network element, network operators can mix and match traffic for maximum efficiency, control, and robustness.

The CPX channelized IP forwarding engine directly interconnects with the DNX cross-connect fabric, distinguishing the Sycamore solution from standalone-DCS-plus-router alternatives that consume more space and power. Using a shared I/O commons, a menu-based user interface (UI), and a single managed device that supports IP/Ethernet SplitE and SplitF provisioning enables faster, more cost-effective delivery of mixed voice and data services. A rich set of IP LAN filters further optimizes performance.

CPX also ensures carrier-class reliability. Innovative IP/Ethernet test access features bring all the circuit-based, carrier-grade diagnostics and test facilities of DNX platforms to packet-switched networks. The DNX/CPX solution extends traditional MonE/F testing to IP/Ethernet, and simplifies Sigtran testing and troubleshooting, with support for simultaneous remote monitoring of up to seven Ethernet ports.

### Features and Benefits

- Consolidates Circuit/Packet Processing Functions
- Enables Cost-Efficient Migration from TDM to IP
- Supports Industry-Unique Test Access for IP
- Maximizes Network Reliability and Scalability
- Increases Provisioning Velocity and Flexibility



### Expanding Applications Flexibility

The ability to groom TDM and Ethernet/IP traffic onto shared T3/E3 or OC-3/STM-1 facilities in a single platform with pay-as-you-grow scalability greatly enhances applications flexibility. DNX/CPX solutions allow incremental, non-disruptive infrastructure changes to support the transition from dedicated, point-to-point digital circuits toward IMS architectures.

#### ■ SS7 to Sigtran Migration

Converting a signaling network from SS7 to IP-based Sigtran introduces serious reliability, scalability, and jurisdiction issues. CPX's integrated packet functionality and optimized ML-PPP link bundle management solve major challenges for IP signaling operations. CPX also ensures mission-critical reliability for SS7 networks and avoids the high CapEx and OpEx of overlay router networks. CPX offers the best of both worlds – the operational efficiencies of IP/Ethernet with DCS reliability and test access features. Equally important, the DNX/CPX solution enables circuit-based network operators to retain authority over the signaling network, rather than relinquishing signaling traffic to IT and data network engineers.

#### ■ DCN Aggregation

Data control network (DCN) communication channels from remote sites consume too much bandwidth and port capacity on core IP routers. CPX efficiently aggregates thousands of DCN circuits and encapsulates them into 10/100BaseT Ethernet transport for efficient handoff to the IP network, substantially reducing port costs and preserving capacity on expensive router platforms. In mobile networks, CPX converges DCN traffic from individual base stations onto a shared IP transport and combines multiple base stations for long-distance backhaul to the MTSO. Low upfront cost, small footprint, and scalable architecture allow cost-effective integration today, and ample room to expand in step with increasing data traffic on mobile backhaul links.

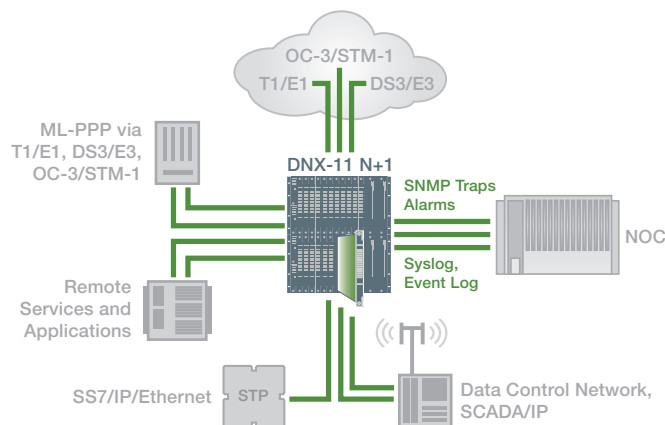

### DNX-11/88 with CPX Simplifies Migration

The CPX module set merges IP/Ethernet traffic with circuit-based services (e.g., SS7/IP, SCADA/IP, EMS/NMS, Mobile Data), supporting smooth network migration within a single network element.

### Carrier-Class Migration Solutions

Deploying a DNX/CPX solution delivers greater reliability, manageability, and affordability than using a digital cross-connect system (DCS), external router, and standalone switch to accomplish the same functions. Today's complex access and mobile RAN applications demand a clear, scalable migration path from TDM to IP. Connection-by-connection, device-by-device, CPX integrates packet technology with intelligent bandwidth management – and gets the job done cost-efficiently in real-world networks.

For more information about our intelligent networking products and solutions, please contact your Sycamore Sales Representative.

## SPECIFICATIONS HIGHLIGHTS

#### CPX Module Set

- Double slot width: Application Module (front card) and Interface Module (rear card) Note: Requires PSX-5300 Protection Switch for cooling

#### Virtual Port Capacity

- 32 PPP links, 8 ML-PPP bundles, 1024 DS0, 32 T1/E1

#### Switch Port Interfaces

- 8 10/100BaseT, fixed or auto-negotiate speed and duplex

#### Connection Method

- 8 individual RJ-45 receptacles for 10/100BaseT, single terminal screw strip x3 for alarm contacts

#### Alarm Contact Inputs

- 3 NO/NC connections for integrated alarming

#### LAN Protocols

- IP filtering, forwarding

#### WAN Protocols

- PPP and ML-PPP

#### IP Test Access

- Multi-port Ethernet MonE/F, IP SplitE, IP SplitF

#### Compliance

- NEBS Level 3 design, FCC Part 15, UL 1950, EU, RoHS, CSA, CE

Sycamore Networks, Inc. • 220 Mill Road • Chelmsford, MA 01824-4144, USA • Phone: 978-250-2900 • Fax: 978-256-3434 • [www.sycamorenet.com](http://www.sycamorenet.com)

Sycamore Networks, Inc. (NASDAQ: SCMR) is a leading provider of intelligent bandwidth management solutions for fixed line and mobile network operators worldwide. From multiservice access networks to the optical core, Sycamore products enable network operators to lower overall network costs, increase operational efficiencies, and rapidly deploy new revenue-generating services.

Sycamore assumes no responsibility for the accuracy of the information presented, which is subject to change without notice. Sycamore and Sycamore Networks are trademarks or registered trademarks of Sycamore Networks, Inc. in the United States and/or other countries. Copyright © 2009 Sycamore Networks, Inc. All Rights Reserved.

